



3,000 LBS WINCHES

NEW ITEMS IN BLUE | UPDATED APPLICATIONS IN RED

BRONCO[®]
ATV & UTV COMPONENTS

GENERATION I WINCH

GENERATION II WINCH

AC-12016 SERIES



AC-12019 SERIES



ALL WINCHES INCLUDE A UNIVERSAL MOUNTING BRACKET, HARDWARE, HANDLEBAR SWITCH, AND ELECTRICAL CONNECTIONS AS FEATURED BELOW

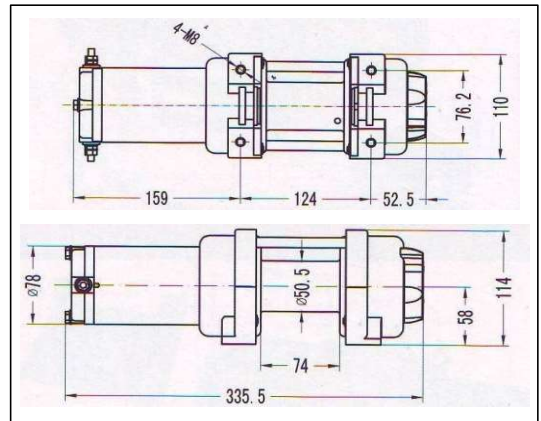

SPECIFICATIONS

| | |
|------------------------------------|--|
| RATED LINE PULL | 3,000 LBS. (1,360KGS.) SINGLE-LINE |
| MOTOR | 12V DC, 1.0HP (770W) PERMANENT MAGNET |
| CONTROLS | HANDLEBAR MOUNTED MINI-ROCKER SWITCH |
| GEARING | 3-STAGE PLANETARY |
| CLUTCH (FREESPOOLING) | CAM ACTIVATED |
| BRAKE | MECHANICAL BRAKE |
| DRUM DIAMETER/ LENGTH | 20" /2,9" |
| ROPE (in X ft) (mm X m) | AC-12016 SERIES: STEEL WIRE, 3/16" X 50' (4.8MM X 15.2M) AC-12019 SERIES: SYNTHETIC ROPE, 3/14" X 33' (5.5MM X 10M) |
| FAIRLEAD | ROLLER |
| GEAR RATIO | 136 : 1 |
| RECOMMENDED BATTERY | 12 AMP/HOUR MINIMUM FOR WINCHING |

PERFORMANCE DATA

| LAYER | RATED LINE PULL LBS (KGS) | TOTAL ROPE ON DRUM FT (M) | LINE PULL LBS (KGS) | LINE SPEED | MOTOR (DRAW) |
|-------|------------------------------|------------------------------|------------------------|---------------|-----------------|
| 1 | 3,000 (1,361) | 8.85 (2.7) | 0 | 27ft (8.3m) | 15 AMPS |
| 2 | 2,561 (1,162) | 19.22 (5.86) | 500 (227) | 20ft (6.1m) | 40 AMPS |
| 3 | 2,234 (1,013) | 31.11 (9.48) | 1,000 (454) | 14ft (4.3m) | 60 AMPS |
| 4 | 1,981 (899) | 44.52 (13.58) | 2,000 (907) | 9ft (2.7m) | 130 AMPS |
| 5 | 1,779 (807) | 50.00 (15.2) | 3,000 (1361) | 5ft (1.5m) | 190 AMPS |