



3,500 LBS WINCHES

NEW ITEMS IN BLUE | UPDATED APPLICATIONS IN RED

BRONCO[®]
ATV & UTV COMPONENTS

GENERATION I WINCH

GENERATION II WINCH

AC-12017 SERIES



AC-12020 SERIES



ALL WINCHES INCLUDE A UNIVERSAL MOUNTING BRACKET, HARDWARE, HANDLEBAR SWITCH, AND ELECTRICAL CONNECTIONS AS FEATURED BELOW

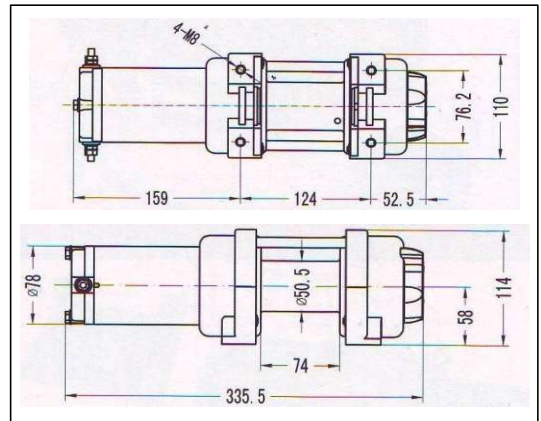

SPECIFICATIONS

RATED LINE PULL	3,500 LBS. (1,581KGS.) SINGLE-LINE
MOTOR	12V DC, 1.1HP (825W) PERMANENT MAGNET
CONTROLS	HANDLEBAR MOUNTED MINI-ROCKER SWITCH
GEARING	3-STAGE PLANETARY
CLUTCH (FREESPOOLING)	CAM ACTIVATED
BRAKE	DYNAMIC MECHANICAL BRAKE IS AVAILABLE
DRUM DIAMETER/ LENGTH	20" /2,9"
ROPE (in X ft) (mm X m)	AC-12017 SERIES: STEEL WIRE, 3/14" X 50' (5.5MM X 15.2M) AC-12020 SERIES: SYNTHETIC ROPE, 3/14" X 33' (5.5MM X 10M)
FAIRLEAD	ROLLER
GEAR RATIO	136 : 1
RECOMMENDED BATTERY	12 AMP/HOUR MINIMUM FOR WINCHING

PERFORMANCE DATA

LAYER	RATED LINE PULL LBS (KGS)	TOTAL ROPE ON DRUM FT (M)	LINE PULL LBS (KGS)	LINE SPEED	MOTOR (DRAW)
1	3,500 (1,581)	8.85 (2.7)	0	27ft (8.3m)	15 AMPS
2	2,561 (1,162)	19.22 (5.86)	500 (227)	20ft (6.1m)	40 AMPS
3	2,234 (1,013)	31.11 (9.48)	1,000 (454)	16ft (4.9m)	60 AMPS
4	1,981 (899)	44.52 (13.58)	2,500 (1134)	7ft (2.1m)	160 AMPS
5	1,779 (807)	50.00 (15.2)	3,500 (1581)	4.3ft (1.3m)	210 AMPS